

**Quantum Devices, Inc.**

“Improving the Quality of Life through the Power in Light”

**QPhase™**

## QD787 20mm (0.787") Diameter Absolute Optical Encoder

### Design Features:

- Miniature Size, 20mm (0.787") Diameter
- 8 bit Gray code or Binary output
- Single turn 8 bit word
- Single ended output
- Patent pending unique sensing system
- Long service life
- Conductive carbon fiber housing
- IP 50 sealing
- High noise immunity
- Low supply current requirements



### Description:

Quantum Devices, Inc. Model QD787 is intended for applications requiring high performance, high-resolution digital feedback in a very small package. The model QD787 provides 8 bit absolute resolution in a package only 20mm (0.787") in diameter. Outputs can be configured in either gray code or binary code. QDI's patent pending sensing scheme embodies a much simplified encoder design, which ultimately results in longer service life, and less down time due to feedback device failure. The encoder housing is constructed of a conductive carbon fiber composite that provides the EMI shielding of an all metal housing and performance of a lightweight robust assembly.

### Ordering Information

**QD787-05/05-A256-04-02-S1**

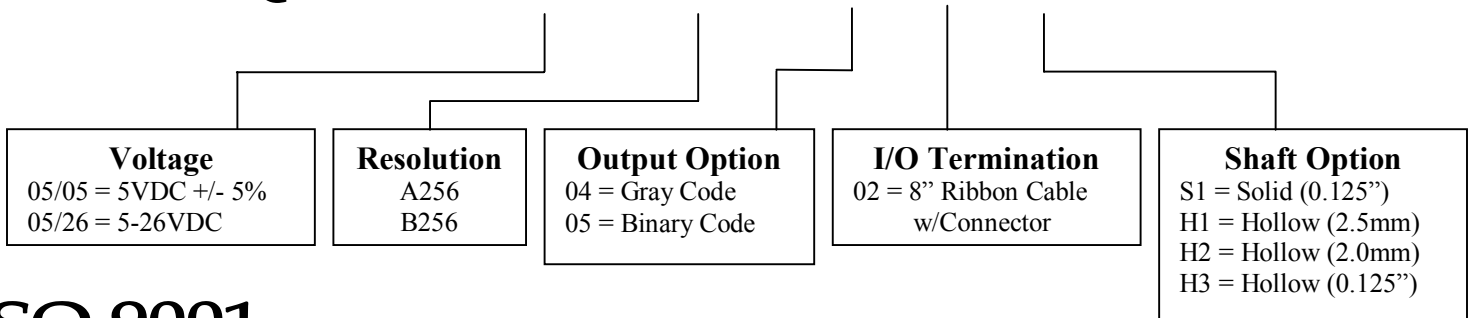

**ISO 9001**

CERT. NO. FM 52711

**Quantum Devices, Inc. 112 Orbison St., P.O. Box 100 , Barneveld, WI 53507**

Tel: (608) 924-3000 Fax: (608) 924-3007 URL: [www.quantumdev.com](http://www.quantumdev.com) E-mail: [qdisales@quantumdev.com](mailto:qdisales@quantumdev.com)

## Electrical Specifications

Input Voltage	5 VDC $\pm$ 5% or 5-26 VDC
Input Current Requirements	40 mA Max. , Plus Interface Loads
Input Ripple	2% Peak to Peak @ 5 VDC
Output Currents	TTL Compatible, VOH >3.80v@-8mA, VOL<0.44v@8mA, VOH >2.50v@-20mA, VOL<0.50v@20mA
Output Format	Gray code or Binary Code 8 bit, single turn, single ended Gray code option utilizes low true Chip Enable (CE') that is pulled down with internal 10K resistor. Positive TTL signal to CE' will force the 8 bit outputs to tri-state condition allowing for shared data paths between encoders, easing basic microprocessor bus interfacing.
Frequency Response	50 kHz
Direction of Rotation	Increasing code values with clockwise rotation (option A256 viewed from flange side) Increasing code values with counterclockwise rotation (option B256 view from flange side)
Positional Accuracy	+/- 0.5LSB Maximum error

## Electrical Connections

Pin #	Gray Code	Binary Code
1	COM	COM
2	+V	+V
3	G <sub>0</sub>	2 <sup>0</sup>
4	G <sub>1</sub>	2 <sup>1</sup>
5	G <sub>2</sub>	2 <sup>2</sup>
6	G <sub>3</sub>	2 <sup>3</sup>
7	G <sub>4</sub>	2 <sup>4</sup>
8	G <sub>5</sub>	2 <sup>5</sup>
9	G <sub>6</sub>	2 <sup>6</sup>
10	G <sub>7</sub>	2 <sup>7</sup>
11	Case	Case
12	CE'	N.C.
13	N.C.	N.C.
14	N.C.	N.C.

## Environmental Specifications

Storage Temperature	-40 to 125° C
Operating Temperature	0 to 70° C Typical -20 to 100° C Optional**
Thermal Shut Down (Total Load Currents = 30mA)	Tamb. Max Vs Input Voltage Max 40°C = 25.0v, 60°C = 20.0v, 80°C = 15.0v, 100°C = 10.0v
Humidity	98% Non-Condensing
Vibration	20 g's @ 50 to 500 CPS
Shock	50 g's @ 11mS Duration

## Mechanical Specification

Maximum Shaft Speed	8000 RPM
Shaft Diameter	0.125"
Shaft Material	Stainless Steel
Bearings	Radial Ball Bearing, R2 type
Radial Shaft Load	2 lbs. Maximum
Axial Shaft Load	1 lbs. Maximum
Housing	Carbon Fiber Composite (case ground via connector)
Housing Volume Resistivity	10 <sup>-2</sup> ohm-cm
Termination	8" Twelve Conductor Ribbon Cable with 2x7 Connector
Mounting	Servo
Moment of Inertia	9.5x10 <sup>-6</sup> oz-in-sec <sup>2</sup>
Acceleration	1x10 <sup>5</sup> Radians per Second <sup>2</sup>

\*\*Contact Factory for more information

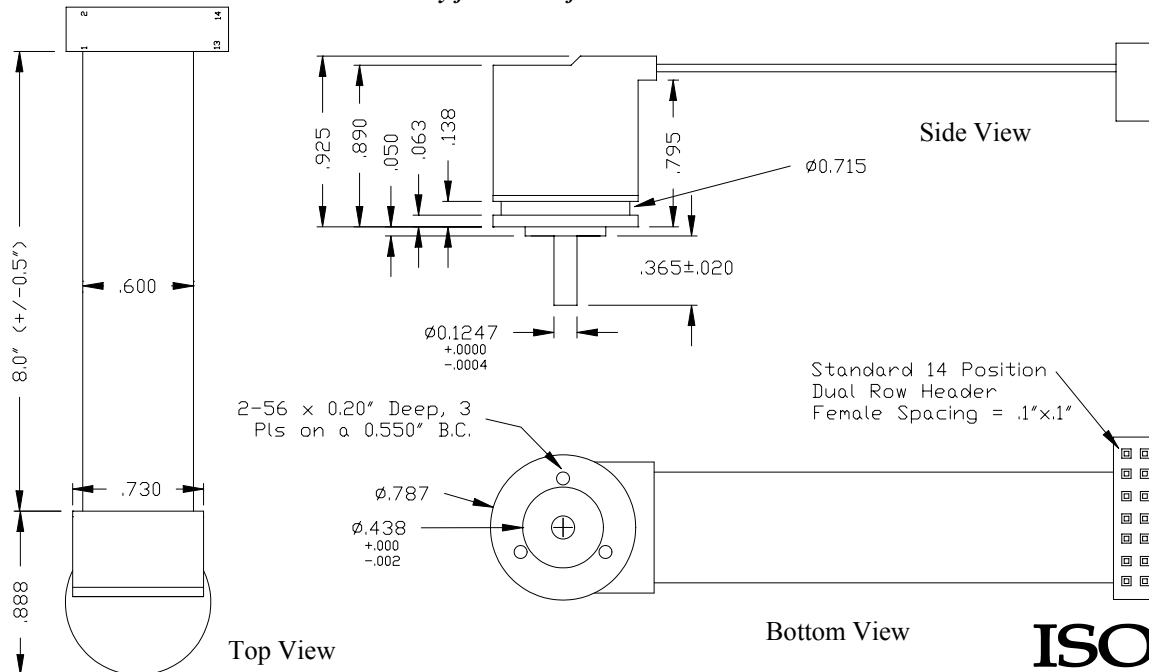

**ISO 9001**  
CERT. NO. FM 52711

**Quantum Devices, Inc. 112 Orbison St., P.O. Box 100 , Barneveld, WI 53507**

Tel: (608) 924-3000 Fax: (608) 924-3007 URL: www.quantumdev.com E-mail: qdisales@quantumdev.com

\*Quantum Devices, Inc. reserves the right to make changes in design, specifications and other information at any time without prior notice. Rev. 020220