

## SC12 (1.22") Diameter Optical Sine/Cosine Encoder

### Design Features:

- Low profile assembled height
- Bearing design simplifies encoder attachment
- Resolutions up to 1250 lines per revolution
- 4, 6 or 8 pole commutation
- Multiple Bolt Circle mounting
- Through shaft sizes up to 0.375" (10mm) Diameter
- High Noise Immunity
- Cost Competitive with Modular Encoders
- 500 kHz Frequency Response
- RoHS Construction



### Description:

Quantum Devices, Inc. Model SC12 provides an improved feedback solution in applications typically using modular encoders. With an over all height of less than one inch and the stability of a bearing encoder design, the model SC12 can provide significant performance upgrades in applications limited by traditional modular encoder solutions. SC-12 Outputs consist of a quadrature sine/cosine pair with an index pulse and three-phase commutation. Each SC-12 is individually calibrated to compensate for normal construction variances. This creates high quality Sin/Cosine outputs that allow for large Count-per-Revolution interpolation factors which are configurable in most of today's sin/cosine drives. Output levels are also stabilized due to source tracking of the sensor supply allowing for compensation of any temperature variation, and aging effects. Differential style outputs provide greater noise immunity and signal integrity. All Outputs are Short-circuit-proof and reverse polarity tolerant. A flexible member allows for much greater tail shaft run out and TIR than can be tolerated by modular encoder designs, plus it provides 30 degrees of rotation for commutation timing.

## Ordering Information

Sample: SC12-1000-4-A-B-L-C-A

Model	PPR	Poles	Electrical	Hub Configuration	Hub Size	Mounting	Index
SC12	256 360 500 512 1000 1024 1250	0= 0 4= 4 6= 6 8= 8	A= Sine/Cosine & RS422 (TTL) UVW  B= Sine/Cosine & OC UVW	B= Bottom Mount Hub with Hole in Cover  C= Bottom Mount Hub with NO Hole in Cover	C= 5mm D= 6mm E= 8mm F= 10mm  L= .25" M= .3125" N= .375"	A= SS 1.812" Flex B= SS 1.575" Flex C= SS 1.280" Flex	A= Ungated Square Wave B= Ungated Sinusoidal

Consult Factory For Configurations Not Shown

## Output Waveforms

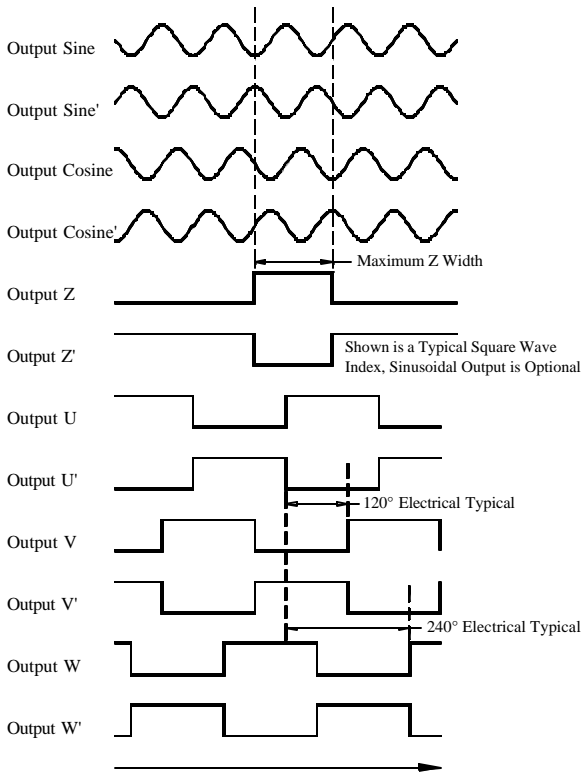

Clockwise Shaft Rotation as Viewed Looking at the Encoder Face. See Figure Below.

CW Rotation for Output Waveforms

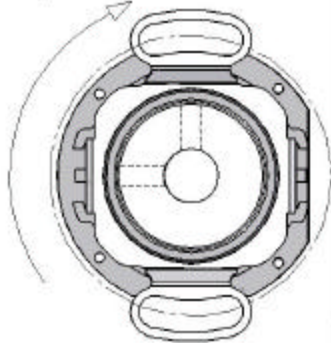

**ISO 9001**  
CERT. NO. FM 52711

## Electrical Specifications

Input Voltage	5 VDC $\pm$ 5%
Input Current Requirements	65mA Typ., 100mA Max Plus Interface Loads
Input Ripple	2% Peak to Peak @ 5 VDC
Output Circuits	(A) Sine/Cosine, Index & RS422 UVW (TTL Compatible) (B) Sine/Cosine, Index & UVW Open Collector
Incremental Output Format	Quadrature Sine/ Cosine with A leading B for CW rotation. Ungated Index Pulse.
Frequency Response	500 kHz
Sine/Cosine & Index Amplitude	1 Vpp $\pm$ 5% (Measured Differentially)
Commutation Format	Three Phase 4, 6 or 8 poles
Commutation Accuracy	$\pm$ 1° mechanical
Z channel to U channel	$\pm$ 1° mechanical

## Environmental Specifications

Storage Temperature	-40 to 125° C
Operating Temperature	-20 to 115° C
IP Rating	40
Humidity	90% Non-Condensing
Vibration	20 g's @ 50 to 500 CPS
Shock	50 g's @ 11mS Duration

## Mechanical Specification

Through Shaft Diameter	0.250", 0.3125", 0.375", 5mm 6mm ,8mm, 10mm Tolerance: -0.0000, + 0.0006"
Recommended Shaft Engagement	.50" Minimum
Radial Shaft Movement	0.007" TIR
Axial Shaft Movement	$\pm$ 0.030"
Maximum Shaft Speed	8000 RPM, Contact Customer Service for Higher RPM
Interface Connector	Connector: JAE P/N F1-W15P-HFE
Mounting	1.28", 1.575", 1.812" Bolt Circle
Moment of Inertia	$9.1 \times 10^{-5}$ oz-in-S <sup>2</sup>
Acceleration	$1 \times 10^5$ Radians/S <sup>2</sup>
Accuracy	Instrument Error 1.5 arc min. max

## 15 Pin Connector JAE P/N: F1-W15P-HFE

Pin Number	Function
1	Sine
2	Sine -
3	Cosine
4	Cosine -
5	Z
6	Z -
7	U
8	U - *
9	V
10	V - *
11	W
12	W - *
13	Vcc
14	GND
15	Open

\* U-, V- and W- not present for open-collector UVW Electrical Option.

## Electrical Output Circuits

A) 1Vpp Sine/Cosine, 26C31 UVW  
B) 1Vpp Sine/Cosine, Open Collector UVW

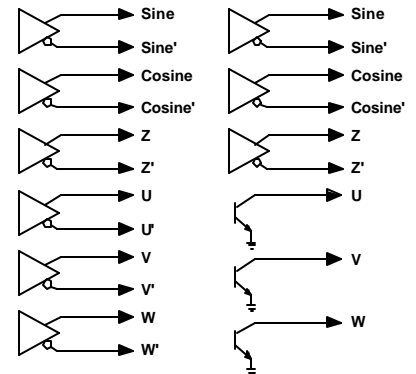

- ◆ 26C31 Sink/Source Current (max) = 20ma (meets RS-422 at 5vdc supply).
- ◆ Open Collector Sink Current (max) = 30ma
- ◆ Open Collector Pull Up Voltage (max) = 30vdc

**Quantum Devices, Inc. 112 Orbison St., P.O. Box 100, Barneveld, WI 53507**

Tel: (608) 924-3000 Fax: (608) 924-3007 URL: www.quantumdev.com E-mail: qdisales@quantumdev.com

\*Quantum Devices, Inc. reserves the right to make changes in design, specifications and other information at any time without prior notice.

# DIMENSIONS

## 1.28 BOLT CIRCLE WITH BOTTOM MOUNT HUB

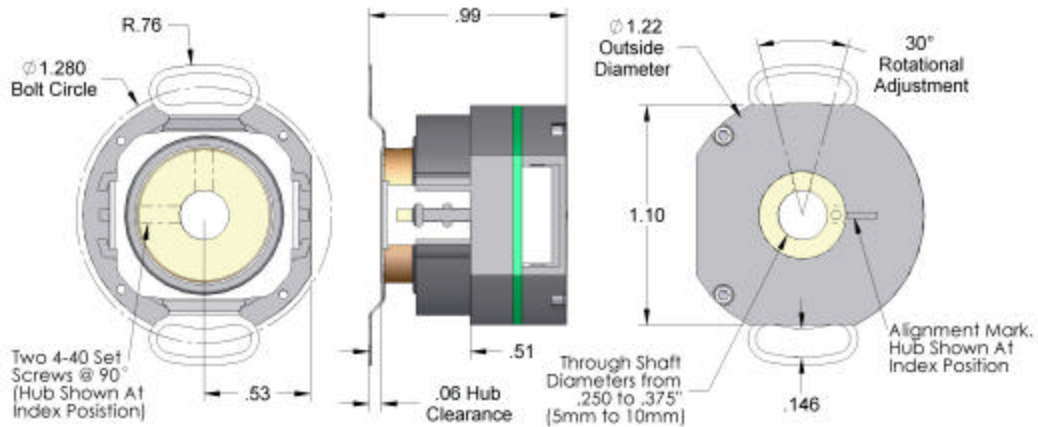

## 1.575 BOLT CIRCLE WITH BOTTOM MOUNT HUB

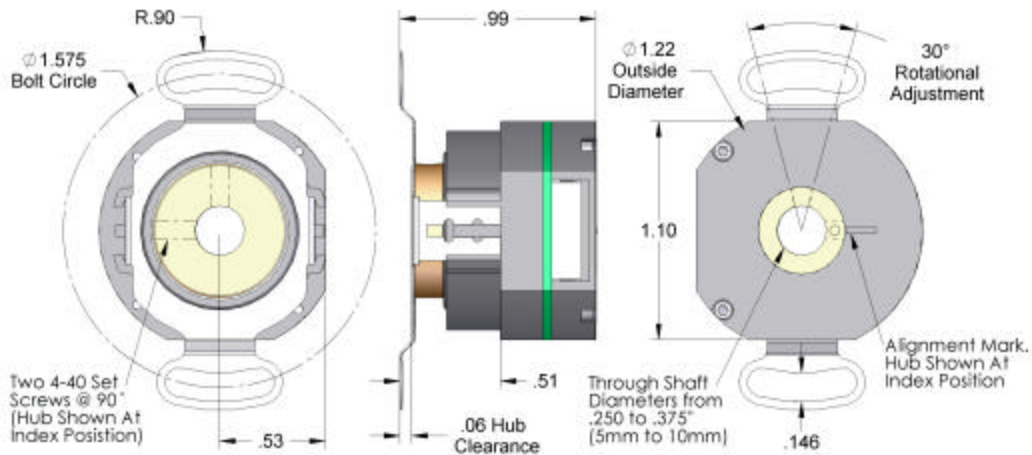

## 1.812 BOLT CIRCLE WITH BOTTOM MOUNT HUB

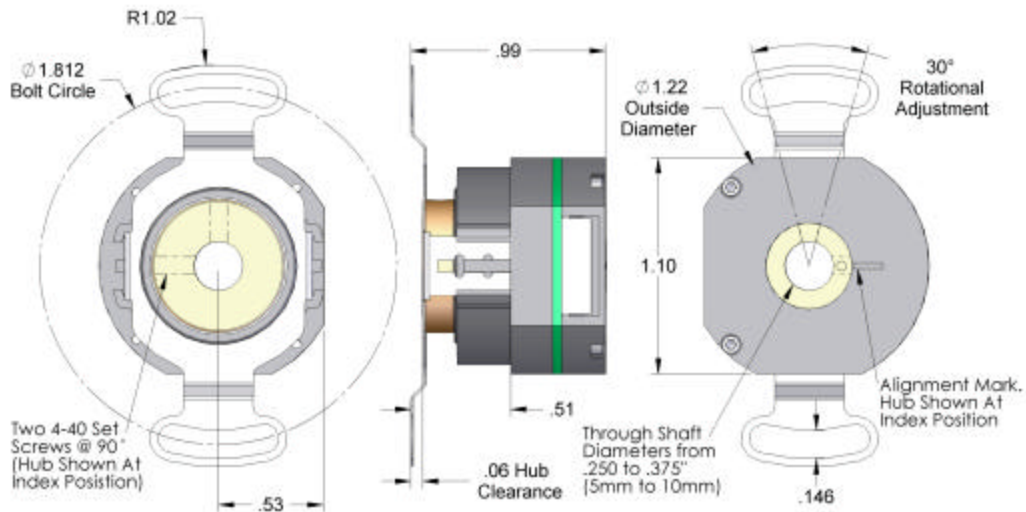

**Quantum Devices, Inc. 112 Orbison St., P.O. Box 100, Barneveld, WI 53507**

Tel: (608) 924-3000 Fax: (608) 924-3007 URL: [www.quantumdev.com](http://www.quantumdev.com) E-mail: [qdisales@quantumdev.com](mailto:qdisales@quantumdev.com)

*\*Quantum Devices, Inc. reserves the right to make changes in design, specifications and other information at any time without prior notice.*

## SIZE 15 RESOLVER MOUNTS

Utilize the optional resolver mount adapters to mate the SC12 - 1.280" Flex mount option to Size 15 Pancake Resolver motor configurations. Eliminate the expensive mounting servo clamps by attaching either the two or three point adapters directly to the servo clamp holes. Assemble the SC12 to the adapter plate using (2) 4-40 screws. For jam nut attachment to threaded motor shafts, refer to JR12 Jam Nut Mount Optical Encoder Literature.

## DIMENSIONS

### Optional Aluminum Resolver Adapters

2074D024 – Two Point 30 Degree  
Commutation Adjustment Range

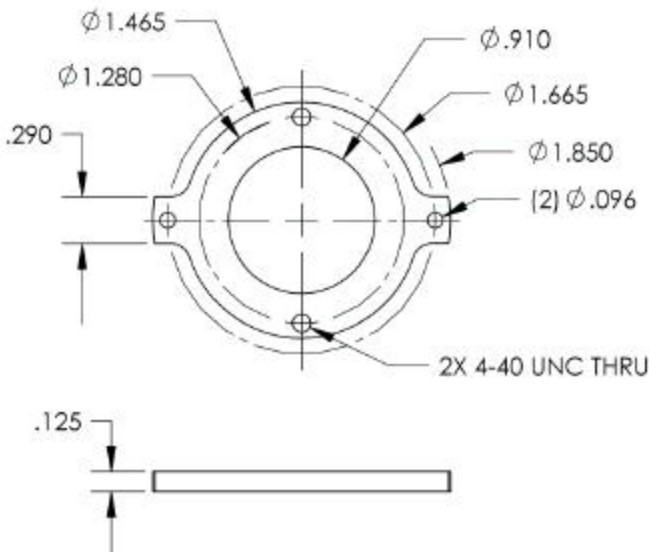

2074D025 – Two Point 360 Degree  
Commutation Adjustment Range

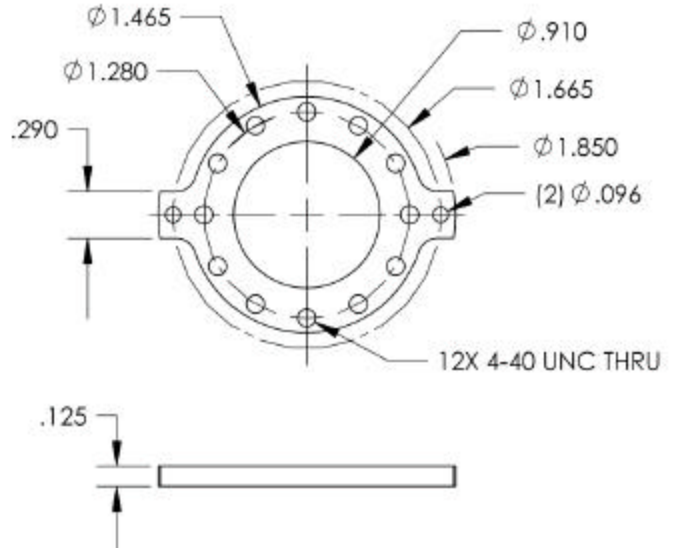

2074D026 – Three Point 30 Degree  
Commutation Adjustment Range

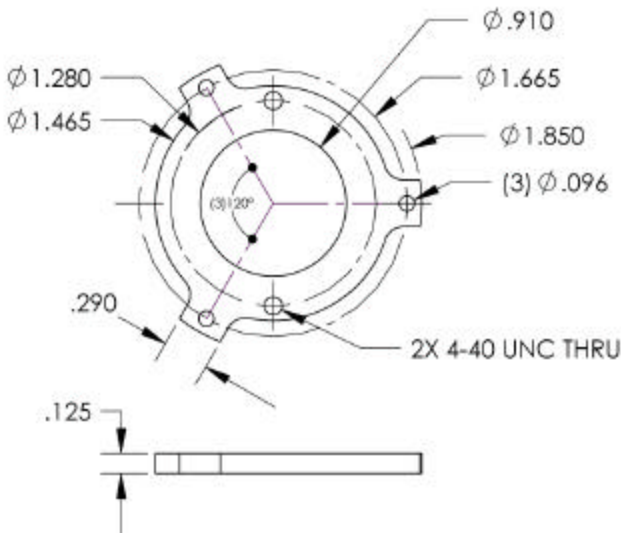

2074D027 – Three Point 360 Degree  
Commutation Adjustment Range

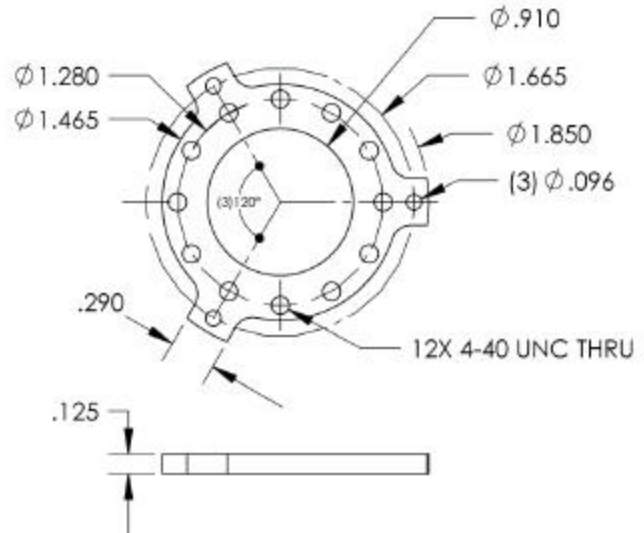

**Quantum Devices, Inc. 112 Orbison St., P.O. Box 100, Barneveld, WI 53507**

Tel: (608) 924-3000 Fax: (608) 924-3007 URL: [www.quantumdev.com](http://www.quantumdev.com) E-mail: [qdisales@quantumdev.com](mailto:qdisales@quantumdev.com)

*\*Quantum Devices, Inc. reserves the right to make changes in design, specifications and other information at any time without prior notice.*

# CABLE OPTIONS

(2080AG039, 2082AG039, 2081AG019, 2083AG019)

Consult Factory for Custom Lengths

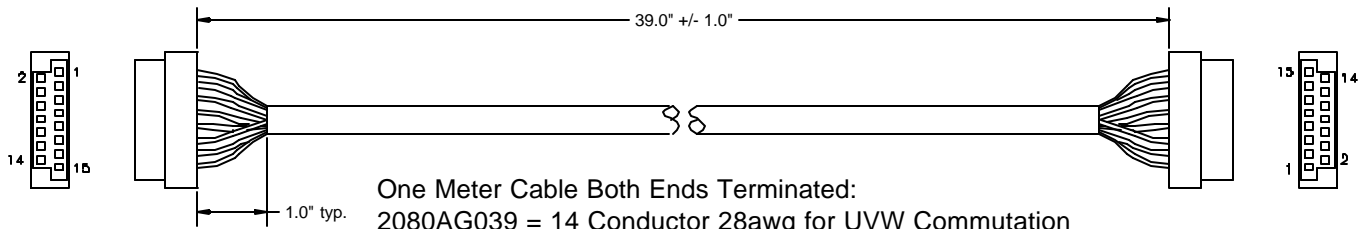

One Meter Cable Both Ends Terminated:  
 2080AG039 = 14 Conductor 28awg for UVW Commutation  
 2082AG039 = 8 Conductor 28awg for Non-Commutation  
 Connector = JAE FI-W15S

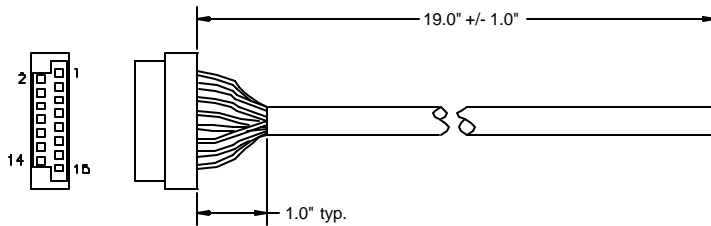

Half Meter Cable One End Terminated:  
 2081AG019 = 14 Conductor 28awg for UVW Commutation  
 2083AG019 = 8 Conductor 28awg for Non-Commutation  
 Connector = JAE FI-W15S

Pin Number	Signal Function	2080AG039	2082AG039
		2081AG019	2083AG019
		Wire Color	Wire Color
1	Sine	Brown	Brown
2	Sine -	White	White
3	Cosine	Blue	Blue
4	Cosine -	Green	Green
5	Z	Orange	Orange
6	Z -	Yellow	Yellow
7	U	Violet	
8	U -	Gray	
9	V	White/Brown	
10	V -	White/Red	
11	W	White/Orange	
12	W -	White/Yellow	
13	Vcc	Red	Red
14	GND	Black	Black
15	No Connect		

Note:

1. Cable has internal foil shield with 28awg drain wire trimmed to jacket edge.
2. Unused wires to be locally isolated from adjacent signal wires, Vcc and GND to prevent damage to encoder signals.

## ENCODER INSTALLTION INSTRUCTIONS

1. Using two fingers slide the encoder onto shaft.
2. For additional security, Loctite can be applied to the encoder hub set screws. Remove the encoder's set screws and using tip of toothpick apply appropriate amount of Loctite thread locking adhesive. A non-permanent adhesive is recommended.
3. Insert and tighten encoder set screws using a .050" hex wrench. Typical torque range of 50 to 80 oz-in.
4. Fixture the stainless steel flex mount to the mounting surface with #6-32 button head screws.

### For brushless motors requiring commutation timing:

- Encoder drawings indicate position of encoder hub to encoder body at Z (index). Rotating the hub to this position allows for known U channel transition state (prior to step one above).
- Powering appropriate motor windings allow for locking motor shaft location to match the appropriate U transition (prior to step one above).
- While mechanically back driving the motor, monitor motor winding EMF position to the powered encoder position. Rotate the encoder stainless steel flex mount to achieve accurate timing of encoder commutation feedback channels to the appropriate motor winding EMF. Tighten the screws retaining the encoder stainless steel flex mounts.

Additional installation and handling instruction available at: [www.quantumdev.com](http://www.quantumdev.com)

**Quantum Devices, Inc. 112 Orbison St., P.O. Box 100, Barneveld, WI 53507**

Tel: (608) 924-3000 Fax: (608) 924-3007 URL: [www.quantumdev.com](http://www.quantumdev.com) E-mail: [qdisales@quantumdev.com](mailto:qdisales@quantumdev.com)

\*Quantum Devices, Inc. reserves the right to make changes in design, specifications and other information at any time without prior notice.

Rev. 080214