

LED THEORY AND APPLICATION NOTES

...GENERAL...

A Light-Emitting-Diode (LED) is a P-N junction device (diode) that gives off light radiation when biased in the forward direction. LED chip materials are combinations of elements from the III and V columns of the periodic chart.

The light emitting phenomenon makes use of the recombination within the P-N junction instead of thermal radiation, therefore, LED's are free of waste and wear and can be expected to have a long life time. By controlling the forward current, the radiant flux of the LED can be easily controlled. The response time of an LED is very high (a few hundred nanoseconds) and can be pulsed at greater forward currents, to obtain high intensity radiant peaks. The resin packaging of LED's allow for superb mechanical integrity and can withstand dropping, vibration and shock. These semiconductor devices can be mounted in any position.

...THEORY...

Just as it takes energy to generate a hole-electron pair, energy is released when an electron recombines with a hole. If a forward current is passed through a semiconductor diode, electrons and holes are injected into the P and N region respectively. Depending on the magnitude of the current, a recombination of charge carriers (electron and holes) takes place when an electron falls from the conduction into the valence band. In silicon and germanium when this recombination takes place, the surplus energy goes into the crystal as heat. In other semiconductors, such as gallium arsenide, the released energy appears in the form of electromagnetic radiation, ranging from visible to infrared. The wavelength of this radiation is dependent on energy required to cause electrons to jump from the conduction band to the valence band.

A portion of the light generated within the LED is unable to emerge due to internal absorption, fresnel losses and internal reflection. Internal absorption occurs as a photon is traveling from the junction region through the chip. Limiting the range of this travel will reduce the internal absorption, thus smaller LED sizes will manifest increased conversion efficiencies. Fresnel losses and internal reflection are minimized by covering the LED chip with an optical coating material whose index of refraction will bridge the indices of refraction between the chip and air.

Light is concentrated near the junction because most of the carriers are to be found within a diffusion length of the junction. Since this junction extends to and is exposed on all four sides of the die, a considerable amount of energy is emitted from the sides as well as the top surface. Typically, the LED chip is mounted in a conical cavity to reflect the side emitting energy forward.

ELECTRICAL CONSIDERATIONS

BASIC DC CIRCUIT

Since LED's are basically diodes, they are current dependent devices and do not have a current control function. When operated from constant voltage sources, protection should be provided by incorporating a current-limiting resistor as shown in figure 1.

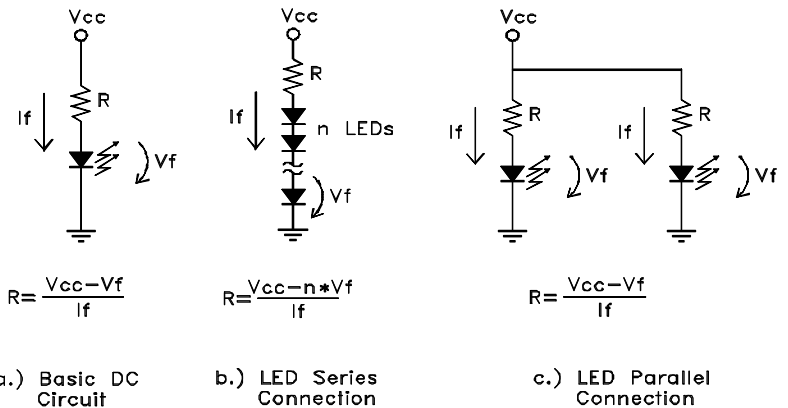

FIGURE 1

Design Example to determine R for figure 1a: Suppose a voltage source of five volts (Vcc) is used and a forward current (If) of 20mA is desired. The data sheet for the LED should indicate an expected voltage drop (Vf) across the LED and for this example 1.5 volts will be used.

$$R = \frac{V_{cc} - V_f}{I_f} \quad R = \frac{5 - 1.5}{.02} \quad R = 175 \text{ ohms}$$

(Equation 1)

LED INTERFACE CIRCUITRY

Constant Current Regulator

CONSTANT CURRENT REGULATORS

This type of DC drive will regulate the current flow through the LED. There are numerous constant current regulator circuits and the circuit shown in figure 2 can be used for a single LED as shown or a number of devices in series.

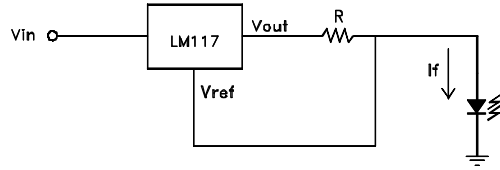

$$I_f = \frac{V_{ref}}{R} = \frac{1.25v}{R}$$

[10mA < I_f < 100mA]

FIGURE 2

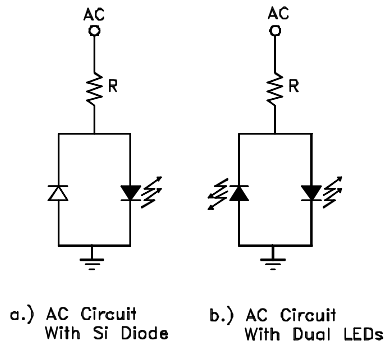

BASIC AC CIRCUIT

Since LED's should be operated in the forward direction, reverse voltage protection is required to assure the reverse voltage (V_r) maximum is not exceeded. Figure 3a illustrates the placement of back-to-back silicon diode across the LED, the silicon diode will clamp the voltage across the LED to approximately .6 volts. Figure 3b shows a different approach that uses two (2) LED's in parallel which alternately light relative to the device under a forward bias condition.

FIGURE 3

BASIC TRANSISTOR DRIVE CIRCUIT

Figure 4a shows a transistor drive circuit that lights the LED when the transistor is conducting into saturation

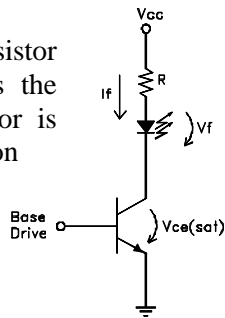

a.) Biased Transistor Drive Circuit

The value R is calculated as shown below:

$$R = \frac{V_{cc} - V_f - V_{ce(sat)}}{I_f}$$

(Equation 2)

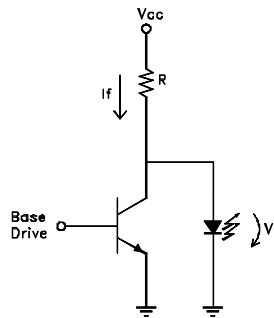

b.) Unbiased Transistor Drive Circuit

Figure 4b shows a transistor drive circuit that lights the LED when the transistor is not conducting or is considered to be open. Equation 1 should be used to determine the value of R. Both of the transistor drive circuits shown in figure 4 can be configured to drive multiple LED's in series

FIGURE 4

PULSED OPERATION

Pulsed operation of LED's can typically be achieved by the transistor drive circuits shown in figure 4. Significantly higher peak LED light output can be realized from large drive current pulses at a low duty cycle. The maximum tolerable limits should not exceed the LED junction temperature above that obtained by operating the lamp at the maximum DC current

LED PACKAGING

LED DIE

The actual size of an LED chip die is typically a cube that is .4mm (.016") on all three sides and is simply illustrated in figure 5. The anode and cathode contacts are opposite each other on the top and bottom of the die. Depending on the processes utilized, anode and cathode contacts can be on either side of the die. The contact to the bottom side is accomplished by using conductive adhesive to attach the die to a conductive substrate. Usually a wire (1 mil in diameter) is fastened to the bond pad on top and is further attached to an external contact or substrate. The bond wire attachment is accomplished using thermal compression or ultrasonic bonding processes.

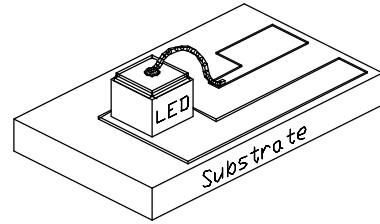

FIGURE 5

CUSTOM PACKAGING

LED die can be assembled onto many different substrates to include; ceramic, metal, printed circuit boards and flex circuits, and can be encapsulated to protect the die and bond wire connection. Many different reflector, lens, and optical configurations can be achieved. Please contact the factory to discuss your application with an engineer.

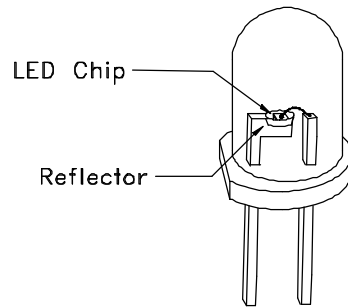

FIGURE 6

COMMON PACKAGING

LED's are commonly packaged in a resin cast or molded plastic enclosure as shown in figure 6. The LED die is attached to the reflector side of a lead frame and a bond wire is attached between the top of the die and the opposite lead frame contact. The lead frame containing the assembled LED proceeds to the final casting or molding process for encapsulation. Typically, the flat side of the package designates the cathode lead. The casting process will form a lens at the tip of the component to maximize light in the forward direction. The shape of the lens and the placement of the lead frame is altered to conform to the desired beam pattern or viewing angle.

RADIOMETRIC MEASUREMENTS

RADIANT FLUX

Radiant Flux is the time rate of flow of radiant energy measured in watts and can be specified as power output. The radiant flux of an LED is measured with an integrating sphere and radiometer combination.

This type of measurement offers a high degree of reproducibility in that nearly all of the power emitted by the integrating spheres consist of two hemispheres that are mated together to form a spherical cavity. The sphere is constructed so that the inner surface consists of a highly reflective diffuse material. Radiation introduced into the sphere and incident upon the surface of the sphere wall is reflected in random directions. The interior of the sphere is characterized by a spatially integrated radiation distribution which is very uniform and this level is proportional to the total amount of radiation introduced into the sphere. A photodetector mounted at a port on the sphere wall to the external radiometer senses the flux density. The measurement of total radiometric flux does not further define spatial distribution or energy contained within angular beam pattern.

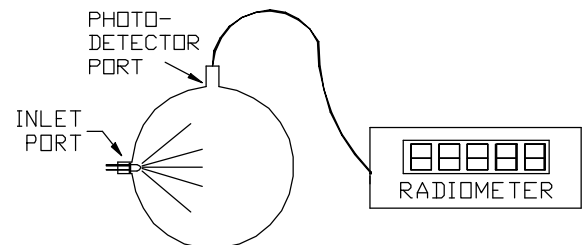

RADIANT INTENSITY

Radiant Intensity is the radiant energy emitted within a time period per unit solid angle, usually measured in watts per steradian. A surface area of a steradian extending from the center of a sphere is equivalent to the square of the radius. There are 4 steradians in a sphere and in a pure cone, a steradian subtends a solid angle of about 66 degrees.

In laymen terms, the measurement procedure is similar to measuring radiant flux. The difference is the photodiode is mounted at a specified distance from, and on the mechanical axis of the LED. An aperture is placed over the photodiode whose opening is the square of the distance from the LED so that only the detector is 10cm and the active area of the detector is one square cm. This results in a solid angle of .01 steradians (fig. 8). The radiant intensity is obtained by using this measured detector value for calculating the radiant intensity for a solid angle of one steradian, i.e. the resultant power measurement is factored by 100 to convert the answer to watts per steradian.

cont. from page 3

This type of measurement results in the on-axis power intensity of the LED over a particular beam angle which is typically a steradian. The radiant intensity value may quantify the requirements for a particular design. The repeatability of the radiant intensity measurement is demanding, due to the difficulty in establishing the mechanical axis.

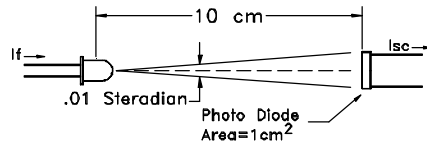

To compute Radiant Intensity (Watts/Sr) for the following conditions:

I_f =Specified Test Current
LED Central Wavelength=730nm
PD Responsivity @730nm=.4Amps/Watt
Resultant I_{sc} =4 μ A
Test Pattern=.01 Steradian

$$\text{Radiant Power To Photo Diode} = \frac{I_{sc}}{\text{PD Responsivity}} = \frac{4\mu\text{A}}{.4\text{A/W}} = .01\text{mWatt}$$

$$\text{Radiant Intensity} = .01\text{mWatt}/.01\text{Sr} = 1\text{mW/Sr}$$

RADIANT INTENSITY MEASUREMENT

FIGURE 8

SOLDERING INSTRUCTIONS

Precaution against overheating must be exercised to prevent damage to the LED. It is recommended the applied heat should be as short as possible and any heat generated be quickly conducted away. Generally a soldering temperature of less than 260 deg. C, at a distance of 2mm from the case, should have a soldering dwell time of less than 3 seconds. Normal flux cleaning processes should be acceptable, however experimentation is recommended.

FOR MORE INFORMATION CONTACT...

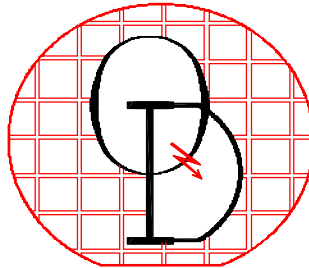

Quantum Devices, Inc.

112 Orbison St.

P.O. Box 100

Barnesville, WI 53507

Tel: (608)924-3000 Fax: (608)924-3007

URL: www.quantumdev.com

E-mail: qdisales@quantumdev.com